



# **EP20K PAC - EP25K PAC** **EP30K PAC - EP35K PAC**

Specifications

**Electric powered lift trucks**  
4 wheel, 2.0 - 3.5 tonnes

Characteristics			Cat Lift Trucks	Cat Lift Trucks		Cat Lift Trucks	Cat Lift Trucks
			EP20K PAC	EP25K PAC		EP30K PAC	EP35K PAC
1.01	Manufacturer (abbreviation)		Battery	Battery		Battery	Battery
1.02	Manufacturer's model designation		Seated	Seated		Seated	Seated
1.03	Power source: (battery, diesel, LP gas, petrol)		2000	2500		3000	3500
1.04	Operator type: pedestrian, (operator)-standing, -seated		500	500		500	500
1.05	Load capacity	Q (kg)	426	426		490	490
1.06	Load centre distance	c (mm)	1520	1520		1690	1690
1.08	Load distance, axle to fork face	x (mm)					
1.09	Wheelbase	y (mm)					
Weight							
2.01	Truck weight, without load / including battery (simplex mast, lowest lift height)	kg	4163	4378		4941	5375
2.02	Axle loading with maximum load, front/rear (simplex mast, lowest lift height)	kg	5263 / 900	6190 / 688		7360 / 580	8164 / 711
2.03	Axle loading without load, front/rear (simplex mast, lowest lift height)	kg	2046 / 2117	2164 / 2214		2595 / 2346	2604 / 2771
Wheels, Drive Train							
3.01	Tyres: V=solid, L=pneumatic, SE=solid pneumatic - front/rear		SE / SE	SE / SE		SE / SE	SE / SE
3.02	Tyre dimensions, front		23 x 9 - 10	23 x 9 - 10		28 x 9 - 15	250 - 15
3.03	Tyre dimensions, rear		18 x 7 - 8	18 x 7 - 8		18 x 7 - 8	18 x 7 - 8
3.05	Number of wheels, front/rear (x=driven)		2x / 2	2x / 2		2x / 2	2x / 2
3.06	Track width (centre of tyres), front	b10 (mm)	990	990		990	990
3.07	Track width (centre of tyres), rear	b11 (mm)	898	898		898	898
Dimensions							
4.01	Mast tilt, forwards/backwards	$\alpha/\beta$ °	6 / 8	6 / 8		6 / 8	6 / 8
4.02	Height with mast lowered (see tables)	h1 (mm)	2142	2142		2155	2284
4.03	Free lift (see tables)	h2 (mm)	100	100		100	100
4.04	Lift height (see tables)	h3 (mm)	3300	3300		3270	3300
4.05	Overall height with mast raised	h4 (mm)	4355	4355		4325	4340
4.07	Height to top of overhead guard	h6 (mm)	2200	2200		2250	2259
4.08	Seat height	h7 (mm)	1105	1105		1155	1164
4.12	Tow coupling height	h10 (mm)	-	-		-	-
4.19	Overall length	l1 (mm)	3319	3344		3592	3647
4.20	Length to fork face (includes fork thickness)	l2 (mm)	2249	2274		2522	2577
4.21	Overall width	b1/b2 (mm)	1190	1190		1230	1230
4.22	Fork dimensions (thickness, width, length)	s / e / l (mm)	40 x 110 x 1070	40 x 110 x 1070		45 x 125 x 1070	45 x 125 x 1070
4.23	Fork carriage to DIN 15 173 A/B/no		2A	2A		3A	3A
4.24	Fork carriage width	b3 (mm)	1000	1000		1000	1000
4.31	Ground clearance under mast, with load	m1 (mm)	110	110		117	117
4.32	Ground clearance at centre of wheelbase, with load (forks lowered)	m2 (mm)	120	120		130	130
4.33	Working aisle width with 1000 x1200 mm pallets, crosswise	Ast (mm)	3576	3596		3870	3920
4.34	Working aisle width with 800 x1200 mm pallets, crosswise	Ast (mm)	3376	3396		3670	3720
4.35	Turning circle radius	Wa (mm)	1950	1970		2180	2230
4.36	Minimum distance between centres of rotation	b13 (mm)	-	-		-	-
Performance							
5.01	Travel speed, with/without load	km/h	20.0 / 20.0	20.0 / 20.0		20.0 / 20.0	16.5 / 18.0
5.02	Lifting speed, with/without load	m/s	0.55 / 0.65	0.50 / 0.65		0.45 / 0.60	0.40 / 0.55
5.03	Lowering speed, with/without load	m/s	0.50 / 0.50	0.50 / 0.50		0.50 / 0.50	0.50 / 0.50
5.05	Rated drawbar pull, with/without load	N	8600 / 8850	8400 / 8900		7500 / 8050	7300 / 8000
5.06	Maximum drawbar pull, with/without load (5 min short duty)	N	12650 / 12750	12200 / 12700		11000 / 11600	10800 / 11500
5.07	Gradeability, with/without load	%	18.7 / 29.4	16.5 / 27.9		12.7 / 22.1	11.1 / 20.1
5.08	Maximum gradeability, with/without load	%	20.9 / 32.9	18.5 / 31.1		14.2 / 24.6	12.5 / 22.4
5.09	Acceleration time (10 metres) with/without load	s	4.1 / 3.6	4.3 / 3.7		5.1 / 4.5	5.2 / 4.6
5.10	Service brakes (mechanical/hydraulic/electric/pneumatic)		Hydraulic	Hydraulic		Hydraulic	Hydraulic
Electric motors							
6.01	Drive motor capacity (60 min. short duty)	kW	14.5	14.5		14.5	14.5
6.02	Lift motor output at 15% duty factor	kW	20.0	20.0		20.0	20.0
6.03	Battery to DIN 43 531/35/36 A/B/C/no		43.536A	43.536A		43.536A	43.536A
6.04	Battery voltage/capacity at 5-hour discharge	V/Ah	80 / 600	80 / 600		80 / 750	80 / 750
6.05	Battery weight	kg	1385	1385		1872	1872
Miscellaneous							
8.01	Type of drive control		MOSFET	MOSFET		MOSFET	MOSFET
8.02	Maximum operating pressure for attachments	bar	185	185		185	185
8.03	Oil flow for attachments	l/min	-	-		-	-
8.04	Noise level, value at operator's ear (EN 12053)	dB(A)	-	-		-	-
8.05	Towing coupling design / DIN type, ref.		-	-		-	-

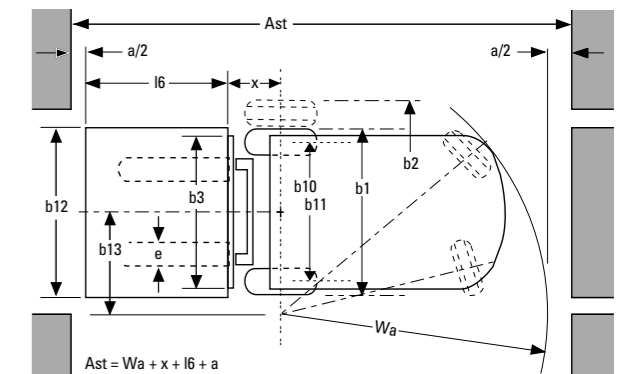
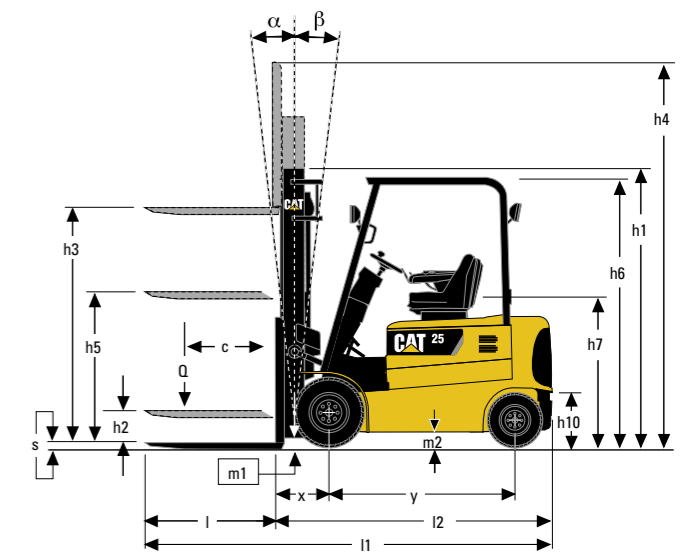

Ast = Working aisle width with load    l6 = Pallet length (800 or 1000 mm)  
a = Safety clearance (200 mm)    b12 = Pallet width (1200 mm)

## Lower Cost of Ownership

- Strong regenerative braking speeds up work cycles, extends battery life and returns energy to the battery. It also reduces heat build-up in the motor and protects components from premature wear, giving better energy efficiency.

## Unmatched Productivity

- Ideal for gradients and applications where the speed and power of an IC engine truck is needed.
- The powerful AC based traction motor is sealed against dust and water splashes and features optimum torque for excellent acceleration, traction, speed and regenerative braking.
- Programmable MOSFET controller features five pre-set operating modes, functions such as traction, lift and tilt can be fine-tuned to precisely match application needs.
- An intelligent monitoring system allows the operator to monitor all major truck functions during normal operation and helps ensure that the truck is serviced in a timely manner.

## Safety and Ergonomics

- The panoramic mast and overhead guard afford excellent overall visibility for safe operation and precise load handling.
- Proportional controlled hydraulics allow sensitive load handling.
- The self-diagnostic routine enables the service engineer to verify proper operation of main systems, components and truck performance settings.

## Options

- Amber strobe light.
- Road lights.



# Cat® Lift Trucks.

## Your partner in materials handling.

EP20K PAC - EP25K PAC					EP20K PAC	EP25K PAC
Mast Type	h3	h1	h4 <sup>1)2)</sup>	h2 / h5 <sup>3)</sup>	Q @ c = 500mm kg	Q @ c = 500mm kg
	mm	mm	mm	mm		
Simplex	2000 <sup>4)</sup>	1495	3055	100	2000	2500
	2570 <sup>4)</sup>	1790	3625	100	2000	2500
	3000 <sup>4)</sup>	1995	4055	100	2000	2500
	3300 <sup>4)</sup>	2145	4355	100	2000	2500
	3740	2410	4795	100	2000	2500
	4100	2590	5155	100	2000	2500
	4500	2800	5555	100	2000	2475
	5000	3050	6055	100	2000	2400
	5500	3300	6555	100	1975	2300
Duplex	3000 <sup>4)</sup>	1995	4055	940	2000	2500
	3300 <sup>4)</sup>	2145	4355	1090	2000	2500
	3700	2410	4755	1355	2000	2500
	4020	2590	5075	1535	2000	2500
Triplex	3730 <sup>4)</sup>	1805	4785	750	2000	2500
	4030 <sup>4)</sup>	1905	5085	850	2000	2500
	4300 <sup>4)</sup>	1995	5355	940	2000	2500
	4750 <sup>4)</sup>	2145	5805	1090	2000	2400
	5060	2265	6115	1210	2000	2325
	5500	2410	6555	1355	1950	2250
	5990	2590	7045	1535	1850	2075
	6500	2850	7555	1795	1525	1675
	7000	3050	8055	1995	1200	1350

EP30K PAC					
Mast Type	h3	h1	h4 <sup>1)2)</sup>	h2 / h5 <sup>3)</sup>	Q @ c = 500mm kg
	mm	mm	mm	mm	
Simplex	2000 <sup>4)</sup>	1530	3055	100	3000
	2560 <sup>4)</sup>	1810	3615	100	3000
	3030 <sup>4)</sup>	2045	4085	100	3000
	3270 <sup>4)</sup>	2165	4325	100	3000
	3700	2430	4755	100	3000
	4000	2610	5055	100	3000
	4500	2870	5555	100	2900
	5000	3120	6055	100	2800
	5500	3370	6555	100	2700
	6000	3635	7055	100	2600
Duplex	3000 <sup>4)</sup>	2035	4055	980	3000
	3250 <sup>4)</sup>	2165	4305	1110	3000
	3700	2430	4755	1375	3000
	4010	2610	5065	1555	3000
Triplex	3690 <sup>4)</sup>	1825	4745	770	3000
	3990 <sup>4)</sup>	1925	5045	870	3000
	4320 <sup>4)</sup>	2045	5375	990	2900
	4700 <sup>4)</sup>	2165	5755	1110	2825
	5060	2285	6115	1230	2750
	5450	2430	6505	1375	2675
	5970	2610	7025	1555	2575
	6470	2870	7525	1815	2475
	7000	3070	8055	2015	2000

EP35K PAC					
Mast Type	h3	h1	h4 <sup>1)2)</sup>	h2 / h5 <sup>3)</sup>	Q @ c = 500mm kg
	mm	mm	mm	mm	
Simplex	2000 <sup>4)</sup>	1460	3055	100	3500
	2570 <sup>4)</sup>	1740	3625	100	3500
	3000 <sup>4)</sup>	2180	4055	100	3500
	3300 <sup>4)</sup>	2300	4355	100	3500
	3720	2510	4775	100	3500
	4000	2765	5055	100	3500
	4500	3010	5555	100	3425
	5000	3260	6055	100	3300
	5500	3510	6555	100	3200
Duplex	3010 <sup>4)</sup>	2180	4065	1125	3500
	3300 <sup>4)</sup>	2300	4355	1245	3500
	3720	2625	4775	1570	3500
	4000	2765	5055	1710	3500
Triplex	3730 <sup>4)</sup>	1940	4785	885	3500
	4010 <sup>4)</sup>	2060	5065	1005	3500
	4390 <sup>4)</sup>	2180	5445	1125	3425
	4700 <sup>4)</sup>	2300	5755	1245	3350
	5030	2445	6085	1390	3275
	5580	2625	6635	1570	3150
	6000	2765	7055	1710	3050
	6510	2940	7565	1885	2725
7000	3135	8055	2080	2100	

Battery Compartment	EP20K PAC	EP25K PAC	EP30K PAC	EP35K PAC
Length (min)	mm	718	718	863
Width (min)	mm	1035	1035	1035
Height (min)	mm	784	784	784
Minimum Weight	kg	1385	1385	1872

### Mast Performance and Capacity

h1	Height with mast lowered
h2	Standard free lift
h3	Standard lift height
h4	Height with mast raised
h5	Full free lift
Q	Lifting capacity, rated load
c	Load centre (distance)

- The h4 dimensions of the simplex mast without load backrest will differ from the table, please consult your dealer for detailed information.
- The h4 dimensions of the duplex/triplex mast without load backrest will differ from the table, please consult your dealer for detailed information.
- The h5 dimensions of the duplex/triplex mast without load backrest will differ from the table, please consult your dealer for detailed information.
- Masts with h1 lower than Overhead Guard Height

catliftruck@mcf.nl  
www.catliftruck.com

CESC0854(01/08)ok  
Copyright ©2008, MCFE. All rights reserved.  
CATERPILLAR, CAT, their respective logos, 'Caterpillar Yellow' and the 'Power Edge' trade dress, as well as corporate and product identity used herein, are trademarks of Caterpillar and may not be used without permission.  
Printed in The Netherlands

NOTE: Performance specifications may vary depending on standard manufacturing tolerances, vehicle condition, types of tyres, floor or surface conditions, applications, or operating environment. Trucks may be shown with non-standard options. Specific performance requirements and locally available configurations should be discussed with your Cat lift trucks Dealer. Cat Lift Trucks follows a policy of continual product improvement. For this reason, some materials, options and specifications could change without notice.



# Ihre Ansprechpartner

## **SG,SH,TG,AI,AR**

André Urech

✉ [aurech@max-urech.ch](mailto:aurech@max-urech.ch)

☎ 056 / 616 70 13

## **OW,NW,LU,ZG,SZ,UR,GR**

Sergio Fazzi

✉ [sfazzi@max-urech.ch](mailto:sfazzi@max-urech.ch)

☎ 056/616 70 35

## **BE,VD,GE,FR,NE,VS,JU**

Markus Grossmann

✉ [mgrossmann@max-urech.ch](mailto:mgrossmann@max-urech.ch)

☎ 079/251 29 32

## **AG,GL,ZH**

Marcel Koch

✉ [mkoch@max-urech.ch](mailto:mkoch@max-urech.ch)

☎ 056/616 70 19

## **BL,BS,BE,FR,SO**

Beat Meyer

✉ [bmeyer@max-urech.ch](mailto:bmeyer@max-urech.ch)

☎ 056/616 70 18

## **TESSIN**

Ugo Toldo

✉ [utoldo@max-urech.ch](mailto:utoldo@max-urech.ch)

☎ 056/616 70 33

## **GE,VD**

Christian Morerod

✉ [cmorerod@max-urech.ch](mailto:cmorerod@max-urech.ch)

☎ 021/701 24 90



**U** max urech

**CAT**  
Lift Trucks